

Activities for Class X

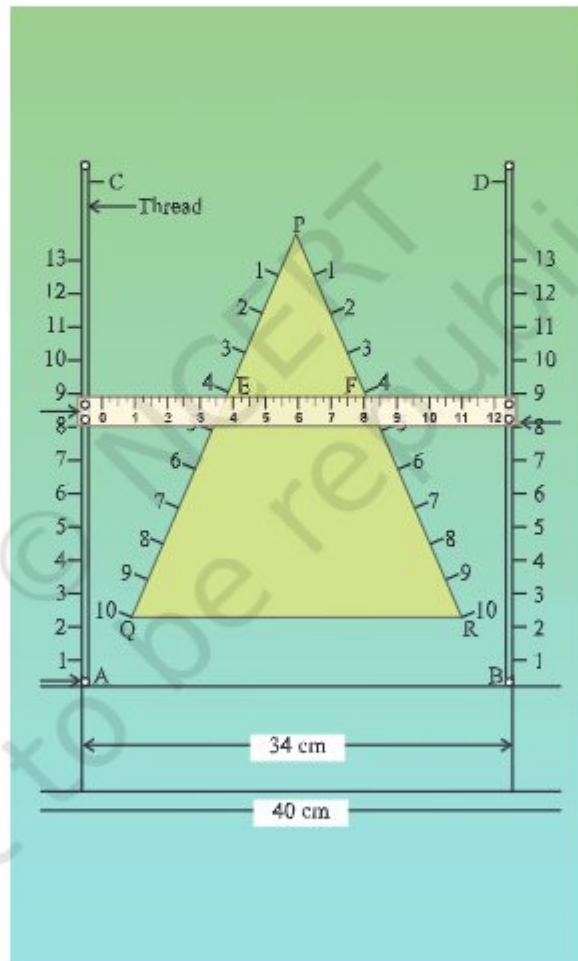

Geometry was always considered more as a discipline of the mind than any other part of mathematics, for it could boast closer relations to logic. Genuine deductivity was the privilege of geometry, whereas the business of algebra was substitution into and transforming formulae. On the other hand the pragmatic point of view would require only a few theorems and not the geometry prescribed by Euclidean tradition. Some people are prepared to teach more useless things in mathematics, but object to geometry being a weak system

– H. Freudenthal.

Activity 1

OBJECTIVE

To find the HCF of two numbers experimentally based on Euclid Division Lemma.

MATERIAL REQUIRED

Cardboard sheets, glazed papers of different colours, scissors, ruler, sketch pen, glue etc.

METHOD OF CONSTRUCTION

1. Cut out one strip of length a units, one strip of length b units ($b < a$), two strips each of length c units ($c < b$), one strip of length d units ($d < c$) and two strips each of length e units ($e < d$) from the cardboard.
2. Cover these strips in different colours using glazed papers as shown in Fig. 1 to Fig. 5:



Fig. 1

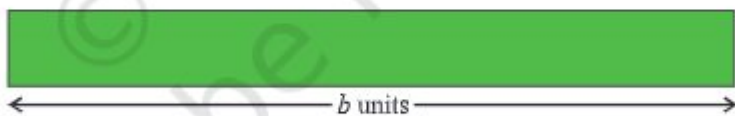

Fig. 2

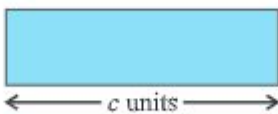
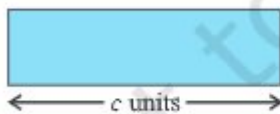

Fig. 3

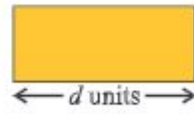

Fig. 4



Fig. 5

3. Stick these strips on the other cardboard sheet as shown in Fig. 6 to Fig. 9.

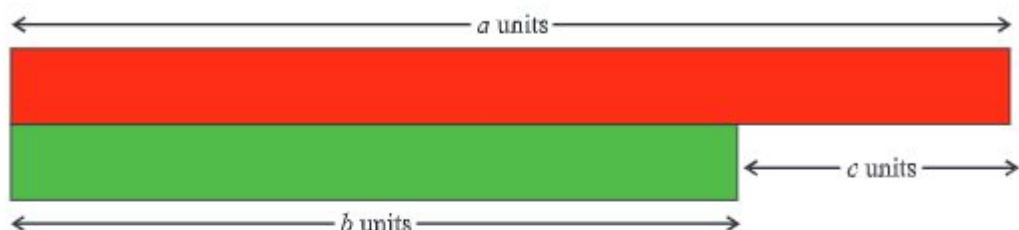

Fig. 6

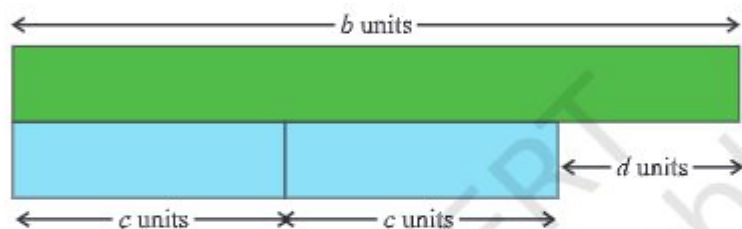

Fig. 7

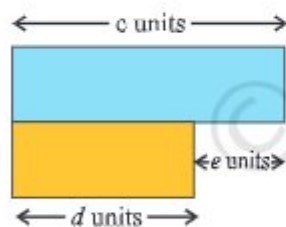

Fig. 8

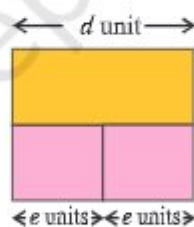

Fig. 9

DEMONSTRATION

As per Euclid Division Lemma,

Fig. 6 depicts $a = b \times 1 + c$ ($q = 1, r = c$) (1)

Fig. 7 depicts $b = c \times 2 + d$ ($q = 2, r = d$) (2)

Fig.8 depicts $c = d \times 1 + e$ ($q = 1, r = e$) (3)

and Fig. 9 depicts $d = e \times 2 + 0$ ($q = 2, r = 0$) (4)

As per assumptions in Euclid Division Algorithm,

$$\begin{aligned} \text{HCF of } a \text{ and } b &= \text{HCF of } b \text{ and } c \\ &= \text{HCF of } c \text{ and } d = \text{HCF of } d \text{ and } e \end{aligned}$$

The HCF of d and e is equal to e , from (4) above.

So, HCF of a and $b = e$.

OBSERVATION

On actual measurement (in mm)

$$a = \dots\dots\dots, \quad b = \dots\dots\dots, \quad c = \dots\dots\dots, \quad d = \dots\dots\dots, \quad e = \dots\dots\dots$$

So, HCF of _____ and _____ =

APPLICATION

The process depicted can be used for finding the HCF of two or more numbers, which is known as finding HCF of numbers by Division Method.

Activity 2

OBJECTIVE

To draw the graph of a quadratic polynomial and observe:

- The shape of the curve when the coefficient of x^2 is positive.
- The shape of the curve when the coefficient of x^2 is negative.
- Its number of zeroes.

MATERIAL REQUIRED

Cardboard, graph paper, ruler, pencil, eraser, pen, adhesive.

METHOD OF CONSTRUCTION

- Take cardboard of a convenient size and paste a graph paper on it.
- Consider a quadratic polynomial $f(x) = ax^2 + bx + c$
- Two cases arise:

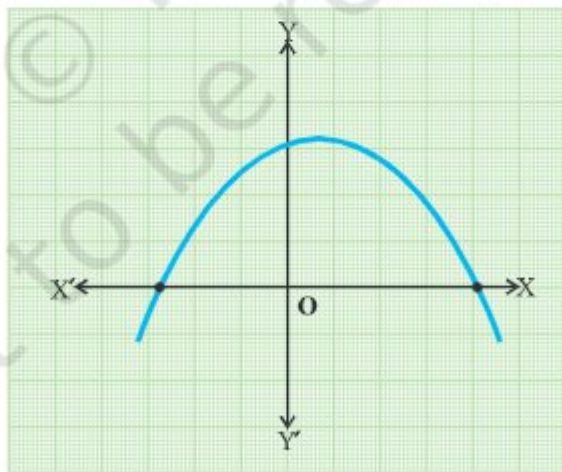

Fig. 1

(i) $a > 0$ (ii) $a < 0$

- Find the ordered pairs $(x, f(x))$ for different values of x .
- Plot these ordered pairs in the cartesian plane.

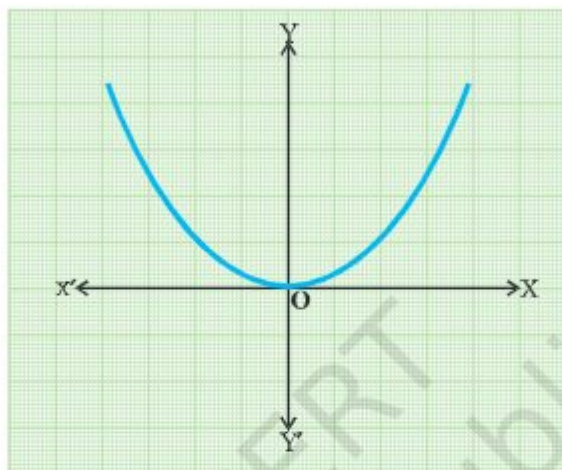

Fig. 2

- Join the plotted points by a free hand curve [Fig. 1, Fig. 2 and Fig. 3].

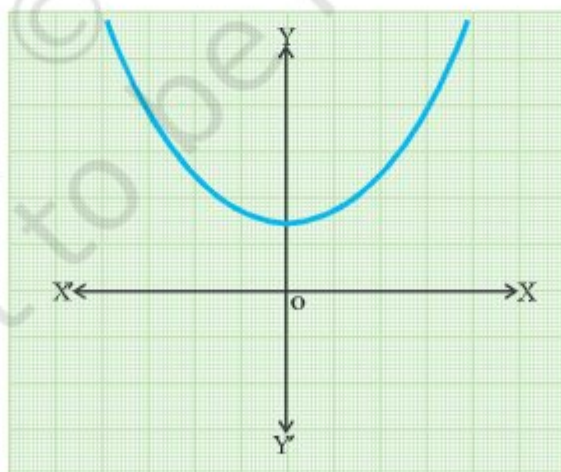

Fig. 3

DEMONSTRATION

1. The shape of the curve obtained in each case is a parabola.
2. Parabola opens upward when coefficient of x^2 is positive [see Fig. 2 and Fig. 3].
3. It opens downward when coefficient of x^2 is negative [see Fig. 1].
4. Maximum number of zeroes which a quadratic polynomial can have is 2.

OBSERVATION

1. Parabola in Fig. 1 opens _____
2. Parabola in Fig. 2 opens _____
3. In Fig. 1, parabola intersects x -axis at _____ point(s).
4. Number of zeroes of the given polynomial is _____.
5. Parabola in Fig. 2 intersects x -axis at _____ point(s).
6. Number of zeroes of the given polynomial is _____.
7. Parabola in Fig.3 intersects x -axis at _____ point(s).
8. Number of zeroes of the given polynomial is _____.
9. Maximum number of zeroes which a quadratic polynomial can have is _____.

APPLICATION

This activity helps in

1. understanding the geometrical representation of a quadratic polynomial
2. finding the number of zeroes of a quadratic polynomial.

NOTE

Points on the graph paper should be joined by a free hand curve only.

Activity 3

OBJECTIVE

To verify the conditions of consistency/inconsistency for a pair of linear equations in two variables by graphical method.

MATERIAL REQUIRED

Graph papers, pencil, eraser, cardboard, glue.

METHOD OF CONSTRUCTION

1. Take a pair of linear equations in two variables of the form

$$a_1x + b_1y + c_1 = 0 \quad (1)$$

$$a_2x + b_2y + c_2 = 0, \quad (2)$$

where a_1, b_1, a_2, b_2, c_1 and c_2 are all real numbers; a_1, b_1, a_2 and b_2 are not simultaneously zero.

There may be three cases :

$$\text{Case I: } \frac{a_1}{a_2} \neq \frac{b_1}{b_2}$$

$$\text{Case II: } \frac{a_1}{a_2} = \frac{b_1}{b_2} = \frac{c_1}{c_2}$$

$$\text{Case III: } \frac{a_1}{a_2} = \frac{b_1}{b_2} \neq \frac{c_1}{c_2}$$

2. Obtain the ordered pairs satisfying the pair of linear equations (1) and (2) for each of the above cases.
3. Take a cardboard of a convenient size and paste a graph paper on it. Draw two perpendicular lines $X'OX$ and YOY' on the graph paper (see Fig. 1). Plot the points obtained in Step 2 on different cartesian planes to obtain different graphs [see Fig. 1, Fig. 2 and Fig.3].

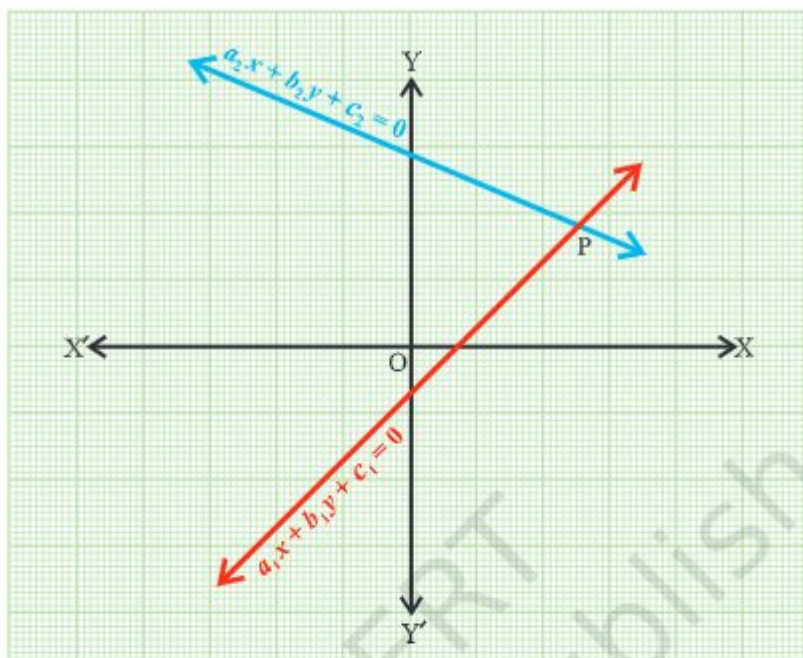

Fig. 1

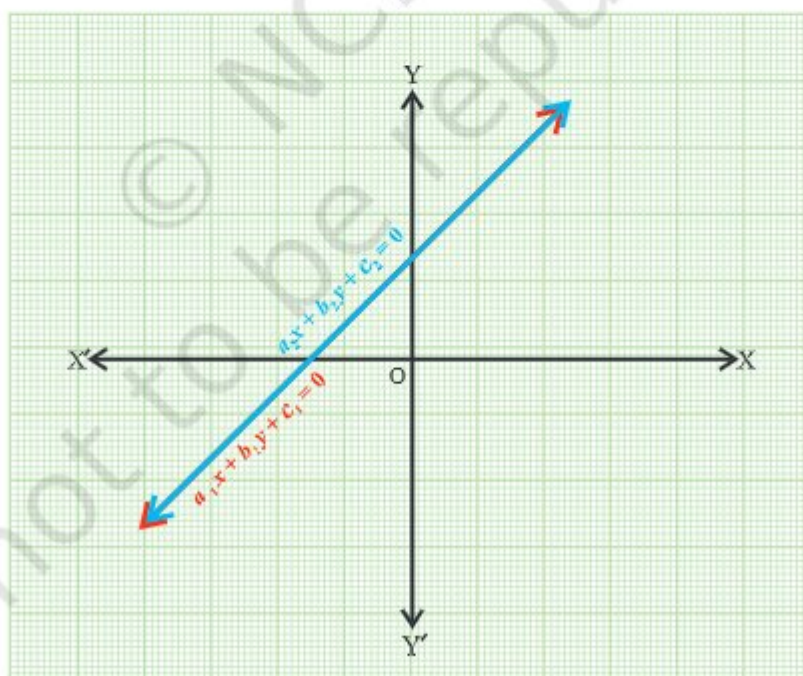

Fig. 2

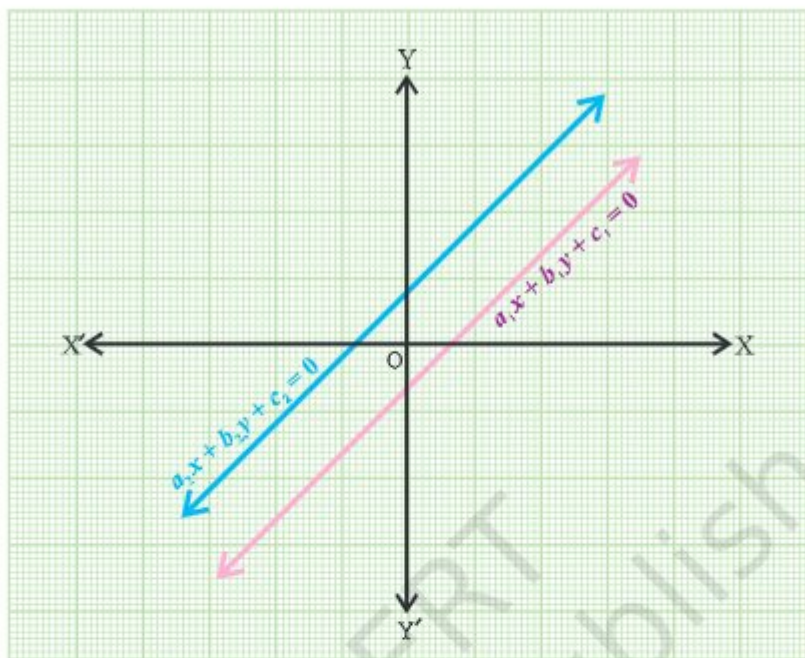

Fig. 3

DEMONSTRATION

Case I: We obtain the graph as shown in Fig. 1. The two lines are intersecting at one point P. Co-ordinates of the point P (x, y) give the unique solution for the pair of linear equations (1) and (2).

Therefore, the pair of linear equations with $\frac{a_1}{a_2} \neq \frac{b_1}{b_2}$ is consistent and has the unique solution.

Case II: We obtain the graph as shown in Fig. 2. The two lines are coincident. Thus, the pair of linear equations has infinitely many solutions.

Therefore, the pair of linear equations with $\frac{a_1}{a_2} = \frac{b_1}{b_2} = \frac{c_1}{c_2}$ is also consistent as well as dependent.

Case III: We obtain the graph as shown in Fig. 3. The two lines are parallel to each other.

This pair of equations has no solution, i.e., the pair of equations with

$$\frac{a_1}{a_2} = \frac{b_1}{b_2} \neq \frac{c_1}{c_2} \text{ is inconsistent.}$$

OBSERVATION

1. $a_1 =$ _____, $a_2 =$ _____,

$b_1 =$ _____, $b_2 =$ _____,

$c_1 =$ _____, $c_2 =$ _____,

So, $\frac{a_1}{a_2} =$, $\frac{b_1}{b_2} =$, $\frac{c_1}{c_2} =$

$\frac{a_1}{a_2}$	$\frac{b_1}{b_2}$	$\frac{c_1}{c_2}$	Case I, II or III	Type of lines	Number of solution	Conclusion Consistent/inconsistent/dependent

APPLICATION

Conditions of consistency help to check whether a pair of linear equations have solution (s) or not.

In case, solutions/solution exist/exists, to find whether the solution is unique or the solutions are infinitely many.

Activity 4

OBJECTIVE

To obtain the solution of a quadratic equation ($x^2 + 4x = 60$) by completing the square geometrically.

MATERIAL REQUIRED

Hardboard, glazed papers, adhesive, scissors, marker, white chart paper.

METHOD OF CONSTRUCTION

1. Take a hardboard of a convenient size and paste a white chart paper on it.
2. Draw a square of side of length x units, on a pink glazed paper and paste it on the hardboard [see Fig. 1]. Divide it into 36 unit squares with a marker.
3. Alongwith each side of the square (outside) paste rectangles of green glazed paper of dimensions $x \times 1$, i.e., 6×1 and divide each of them into unit squares with the help of a marker [see Fig. 1].
4. Draw 4 squares each of side 1 unit on a yellow glazed paper, cut them out and paste each unit square on each corner as shown in Fig. 1.

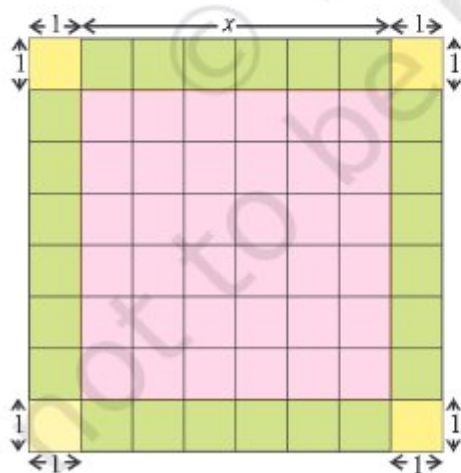

Fig. 1

$$x^2 + 4x + 4 = 64$$

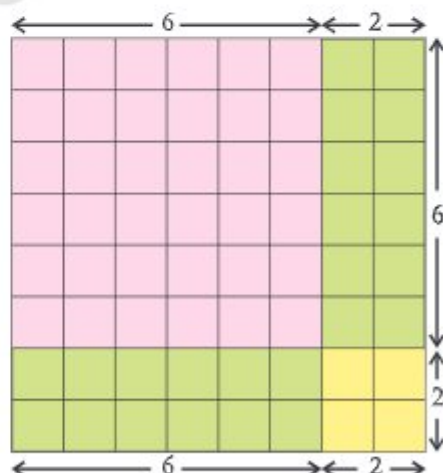

Fig. 2

5. Draw another square of dimensions 8×8 and arrange the above 64 unit squares as shown in Fig. 2.

DEMONSTRATION

1. The first square represents total area $x^2 + 4x + 4$.
2. The second square represents a total of 64 ($60 + 4$) unit squares.

Thus, $x^2 + 4x + 4 = 64$

or $(x + 2)^2 = (8)^2$ or $(x + 2) = \pm 8$

i.e., $x = 6$ or $x = -10$

Since x represents the length of the square, we cannot take $x = -10$ in this case, though it is also a solution.

OBSERVATION

Take various quadratic equations and make the squares as described above, solve them and obtain the solution(s).

APPLICATION

Quadratic equations are useful in understanding parabolic paths of projectiles projected in the space in any direction.

Activity 5

OBJECTIVE

To identify Arithmetic Progressions in some given lists of numbers (patterns).

MATERIAL REQUIRED

Cardboard, white paper, pen/pencil, scissors, squared paper, glue.

METHOD OF CONSTRUCTION

1. Take a cardboard of a convenient size and paste a white paper on it.
2. Take two squared papers (graph paper) of suitable size and paste them on the cardboard.



Fig. 1



Fig. 2

3. Let the lists of numbers be
 - (i) 1, 2, 5, 9,
 - (ii) 1, 4, 7, 10,
4. Make strips of lengths 1, 2, 5, 9 units and strips of lengths 1, 4, 7, 10 units and breadth of each strip one unit.
5. Paste the strips of lengths 1, 2, 5, 9 units as shown in Fig. 1 and paste the strips of lengths 1, 4, 7, 10 units as shown in Fig. 2.

DEMONSTRATION

1. In Fig. 1, the difference of heights (lengths) of two consecutive strips is not same (uniform). So, it is not an AP.
2. In Fig. 2, the difference of heights of two consecutive strips is the same (uniform) throughout. So, it is an AP.

OBSERVATION

In Fig. 1, the difference of heights of first two strips = _____

the difference of heights of second and third strips = _____

the difference of heights of third and fourth strips = _____

Difference is _____ (uniform/not uniform)

So, the list of numbers 1, 2, 5, 9 _____ form an AP. (does/does not)

Write the similar observations for strips of Fig.2.

Difference is _____ (uniform/not uniform)

So, the list of the numbers 1, 4, 7, 10 _____ form an AP. (does/does not)

APPLICATION

This activity helps in understanding the concept of arithmetic progression.

NOTE

Observe that if the left top corners of the strips are joined, they will be in a straight line in case of an AP.

Activity 6

OBJECTIVE

To find the sum of first n natural numbers.

MATERIAL REQUIRED

Cardboard, coloured papers, white paper, cutter, adhesive.

METHOD OF CONSTRUCTION

1. Take a rectangular cardboard of a convenient size and paste a coloured paper on it. Draw a rectangle ABCD of length 11 units and breadth 10 units.
2. Divide this rectangle into unit squares as shown in Fig. 1.
3. Starting from upper left-most corner, colour one square, 2 squares and so on as shown in the figure.

DEMONSTRATION

1. The pink colour region looks like a stair case.
2. Length of 1st stair is 1 unit, length of 2nd stair is 2 units, length of 3rd stair 3 units, and so on, length of 10th stair is 10 units.

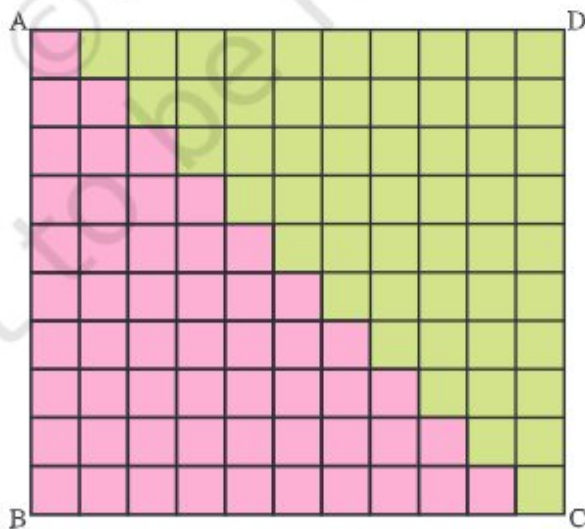

Fig. 1

3. These lengths give a pattern

1, 2, 3, 4, ..., 10,

which is an AP with first term 1 and common difference 1.

4. Sum of first ten terms

$$= 1 + 2 + 3 + \dots + 10 = 55 \quad (1)$$

Area of the shaded region = $\frac{1}{2}$ (area of rectangle ABCD)

= $\frac{1}{2} \times 10 \times 11$, which is same as obtained in (1) above. This shows that the

sum of the first 10 natural numbers is $\frac{1}{2} \times 10 \times 11 = \frac{1}{2} \times 10(10+1)$.

This can be generalised to find the sum of first n natural numbers as

$$S_n = \frac{1}{2} n(n+1) \quad (2)$$

OBSERVATION

For $n = 4$, $S_n = \dots$

For $n = 12$, $S_n = \dots$

For $n = 50$, $S_n = \dots$

For $n = 100$, $S_n = \dots$

APPLICATION

Result (2) may be used to find the sum of first n terms of the list of numbers:

1. $1^2, 2^2, 3^2, \dots$

2. $1^3, 2^3, 3^3, \dots$

to be studied in Class XI.

Activity 7

OBJECTIVE

To find the sum of the first n odd natural numbers.

MATERIAL REQUIRED

Cardboard, thermocol balls, pins, pencil, ruler, adhesive, white paper.

METHOD OF CONSTRUCTION

1. Take a piece of cardboard of a convenient size and paste a white paper on it.
2. Draw a square of suitable size on it (10 cm \times 10 cm).
3. Divide this square into unit squares.
4. Fix a thermocol ball in each square with the help of a pin as shown in Fig. 1.
5. Enclose the balls as shown in the figure.

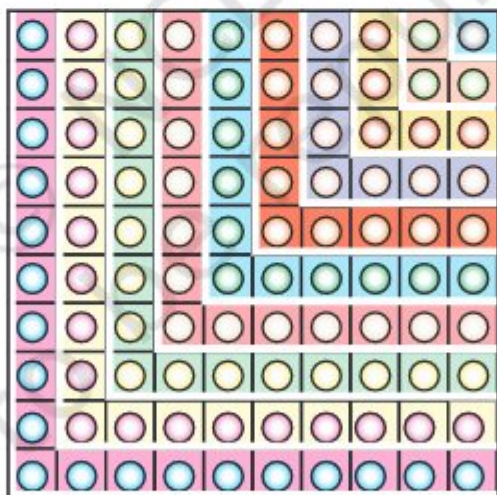

Fig. 1

DEMONSTRATION

Starting from the uppermost right corner, the number of balls in first enclosure (blue colour) = 1 ($=1^2$),

the number of balls in first 2 enclosures = $1 + 3 = 4 (=2^2)$,

the number of balls in first 3 enclosures = $1 + 3 + 5 = 9 (=3^2)$,

the number of balls in first 10 enclosures = $1 + 3 + 5 + \dots + 19 = 100 (=10^2)$.

This gives the sum of first ten odd natural numbers. This result can be generalised for the sum of first n odd numbers as:

$$S_n = 1 + 3 + \dots + (2n - 1) = n^2 \quad (1)$$

OBSERVATION

For $n = 4$ in (1), $S_n = \dots\dots\dots$

For $n = 5$ in (1), $S_n = \dots\dots\dots$

For $n = 50$ in (1), $S_n = \dots\dots\dots$

For $n = 100$ in (1), $S_n = \dots\dots\dots$

APPLICATION

The activity is useful in determining formula for the sum of the first n odd natural numbers.

Activity 8

OBJECTIVE

To find the sum of the first n -even natural numbers.

MATERIAL REQUIRED

Cardboard, thermocol balls, pins, pencil, ruler, white paper, chart paper, adhesive.

METHOD OF CONSTRUCTION

1. Take a piece of cardboard of a convenient size and paste a white paper on it.
2. Draw a rectangle of suitable size on it (10 cm \times 11 cm).
3. Divide this rectangle into unit squares.
4. Fix a thermocol ball in each square using a pin as shown in the Fig. 1.
5. Enclose the balls as shown in the figure.

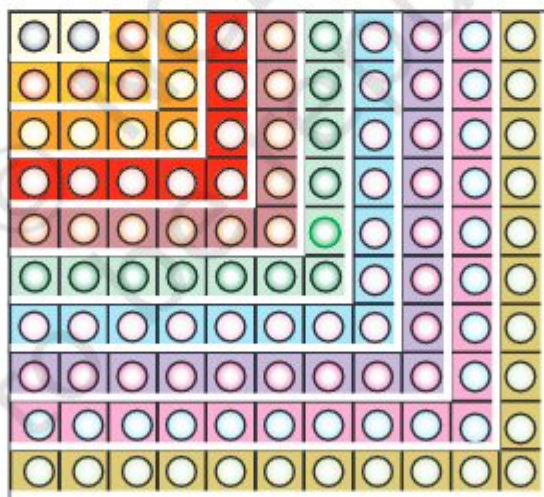

Fig. 1

DEMONSTRATION

Starting from the uppermost left corner,

the number of balls in first enclosure = 2 (= 1 × 2),

the number of balls in first two enclosures = 2 + 4 = 6 (= 2 × 3),

the number of balls in first three enclosures = 2 + 4 + 6 = 12 (= 3 × 4),

⋮

the number of balls in first six enclosures = 2 + 4 + 6 + 8 + 10 + 12 = 42 (= 6 × 7)

the number of balls in first ten enclosures = 2 + 4 + 6 + 8 + ... + 20 = 110 (= 10 × 11)

This gives the sum of first ten even natural numbers.

This result can be generalised for the sum of first n even natural numbers as

$$S_n = 2 + 4 + 6 + \dots + 2n = n \times (n + 1) \quad (1)$$

OBSERVATION

For $n = 4$ in (1), $S_n = \dots$

For $n = 7$ in (1), $S_n = \dots$

For $n = 40$ in (1), $S_n = \dots$

For $n = 70$ in (1), $S_n = \dots$

For $n = 100$ in (1), $S_n = \dots$

APPLICATION

The formula $S_n = n(n+1)$ is useful in finding out the sum of the first n even numbers.

Activity 9

OBJECTIVE

To establish a formula for the sum of first n terms of an Arithmetic Progression.

MATERIAL REQUIRED

Cardboard, coloured drawing sheets, white paper, cutter, adhesive.

METHOD OF CONSTRUCTION

1. Take a rectangular cardboard of a convenient size and paste a white paper on it. Draw a rectangle ABCD of length $(2a+9d)$ units and breadth 10 units.
2. Make some rectangular strips of equal length a units and breadth one unit and some strips of length d units and breadth 1 unit, using coloured drawing sheets.
3. Arrange/paste these strips on the rectangle ABCD as shown in Fig. 1.

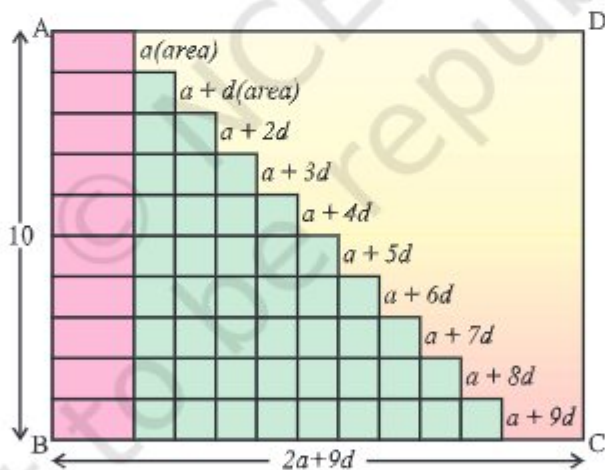

Fig. 1

DEMONSTRATION

1. The strips so arranged look like a stair case.
2. The first stair is of length a units, the second stair is of length $a+d$ (units), third of $a+2d$ units and so on and each is of breadth 1 unit. So, the areas (in sq. units) of these strips are $a, a+d, a+2d, \dots, a+9d$, respectively.

3. This arrangement of strips gives a pattern $a, a + d, a + 2d, a + 3d, \dots$ which is an AP with first term a and the common difference d .
4. The sum of the areas (in square units) of these strips
 $= a + (a + d) + (a + 2d) + \dots + (a + 9d) = 10a + 45d$ (1)
5. Area of the designed formed by the stair case $= \frac{1}{2}$ (area of rectangle ABCD)
 $= \frac{1}{2}(10)(2a + 9d)$
 $= (10a + 45d)$, which is the same as obtained in (1) above.

This shows that the sum of first 10 terms of the AP $= \frac{1}{2}(10)(2a + 9d)$
 $= \frac{1}{2}(10) [2a + (10 - 1)d]$

This can be further generalised to find the sum of first n terms of an AP as

$$S_n = \frac{n}{2} [2a + (n - 1)d]$$

OBSERVATION

On actual measurement:

$$a = \text{-----}, \quad d = \text{-----}, \quad n = \text{-----} \quad S_n = \text{-----}$$

$$\text{So, } S_n = \frac{n}{2} [- + (n - 1)-].$$

APPLICATION

This result may be used to find the sum of first n terms of the list of numbers :

1. $1^2, 2^2, 3^2, \dots$ 2. $1^3, 2^3, 3^3, \dots$

to be studied in Class XI.

Activity 10

OBJECTIVE

To verify the distance formula by graphical method.

MATERIAL REQUIRED

Cardboard, chart paper, graph paper, glue, pen/pencil and ruler.

METHOD OF CONSTRUCTION

1. Paste a chart paper on a cardboard of a convenient size.
2. Paste the graph paper on the chart paper.
3. Draw the axes $X'OX$ and $Y'OY$ on the graph paper [see Fig. 1].
4. Take two points $A(a, b)$ and $B(c, d)$ on the graph paper and join them to get a line segment AB [see Fig. 2].

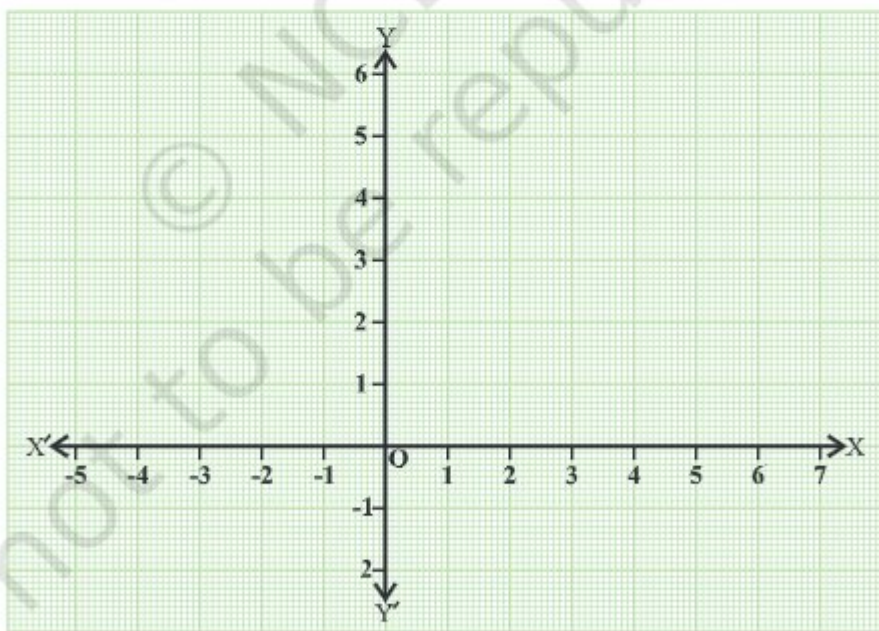

Fig. 1

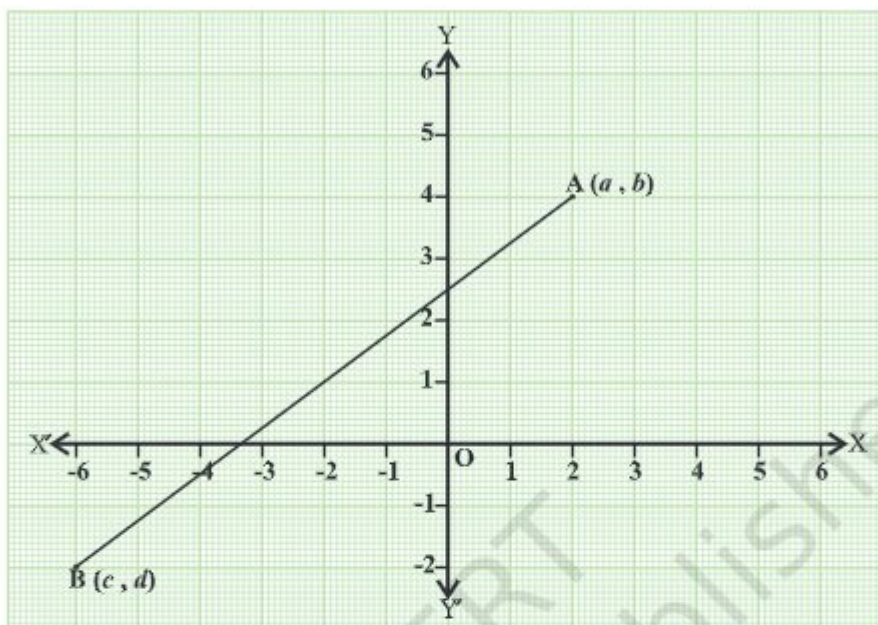

Fig. 2

DEMONSTRATION

1. Calculate the distance AB using distance formula.
2. Measure the distance between the two points A and B using a ruler.
3. The distance calculated by distance formula and distance measured by the ruler are the same.

OBSERVATION

1. Coordinates of the point A are _____.
Coordinates of the point B are _____.
2. Distance AB, using distance formula is _____.
3. Actual distance AB measured by ruler is _____.
4. The distance calculated in (2) and actual distance measured in (3) are _____.

APPLICATION

The distance formula is used in proving a number of results in geometry.